

Making Everything Easier!™

3D Printing

FOR
DUMMIES[®]
A Wiley Brand

Learn to:

- Use 3D printing software, hardware, and tools
- Work with the different types of 3D printing processes and services
- Follow best practices for 3D printing
- Create your own RepRap 3D printer

Kalani Kirk Hausman
Richard Horne



Get More and Do More at Dummies.com®



Start with **FREE** Cheat Sheets

Cheat Sheets include

- Checklists
- Charts
- Common Instructions
- And Other Good Stuff!

To access the Cheat Sheet created specifically for this book, go to
www.dummies.com/cheatsheet/3dprinting

Get Smart at Dummies.com

Dummies.com makes your life easier with 1,000s of answers on everything from removing wallpaper to using the latest version of Windows.

Check out our

- Videos
- Illustrated Articles
- Step-by-Step Instructions

Plus, each month you can win valuable prizes by entering our Dummies.com sweepstakes. *

Want a weekly dose of Dummies? Sign up for Newsletters on

- Digital Photography
- Microsoft Windows & Office
- Personal Finance & Investing
- Health & Wellness
- Computing, iPods & Cell Phones
- eBay
- Internet
- Food, Home & Garden

Find out "HOW" at Dummies.com

*Sweepstakes not currently available in all countries; visit Dummies.com for official rules.





**by Kalani Kirk Hausman
and
Richard Horne**



3D Printing For Dummies®

Published by: **John Wiley & Sons, Inc.**, 111 River Street, Hoboken, NJ 07030-5774, www.wiley.com

Copyright © 2014 by John Wiley & Sons, Inc., Hoboken, New Jersey

Published simultaneously in Canada

No part of this publication may be reproduced, stored in a retrieval system or transmitted in any form or by any means, electronic, mechanical, photocopying, recording, scanning or otherwise, except as permitted under Sections 107 or 108 of the 1976 United States Copyright Act, without the prior written permission of the Publisher. Requests to the Publisher for permission should be addressed to the Permissions Department, John Wiley & Sons, Inc., 111 River Street, Hoboken, NJ 07030, (201) 748-6011, fax (201) 748-6008, or online at <http://www.wiley.com/go/permissions>.

Trademarks: Wiley, For Dummies, the Dummies Man logo, Dummies.com, Making Everything Easier, and related trade dress are trademarks or registered trademarks of John Wiley & Sons, Inc. and may not be used without written permission. All other trademarks are the property of their respective owners. John Wiley & Sons, Inc. is not associated with any product or vendor mentioned in this book.

LIMIT OF LIABILITY/DISCLAIMER OF WARRANTY: THE PUBLISHER AND THE AUTHOR MAKE NO REPRESENTATIONS OR WARRANTIES WITH RESPECT TO THE ACCURACY OR COMPLETENESS OF THE CONTENTS OF THIS WORK AND SPECIFICALLY DISCLAIM ALL WARRANTIES, INCLUDING WITHOUT LIMITATION WARRANTIES OF FITNESS FOR A PARTICULAR PURPOSE. NO WARRANTY MAY BE CREATED OR EXTENDED BY SALES OR PROMOTIONAL MATERIALS. THE ADVICE AND STRATEGIES CONTAINED HEREIN MAY NOT BE SUITABLE FOR EVERY SITUATION. THIS WORK IS SOLD WITH THE UNDERSTANDING THAT THE PUBLISHER IS NOT ENGAGED IN RENDERING LEGAL, ACCOUNTING, OR OTHER PROFESSIONAL SERVICES. IF PROFESSIONAL ASSISTANCE IS REQUIRED, THE SERVICES OF A COMPETENT PROFESSIONAL PERSON SHOULD BE SOUGHT. NEITHER THE PUBLISHER NOR THE AUTHOR SHALL BE LIABLE FOR DAMAGES ARISING HEREFROM. THE FACT THAT AN ORGANIZATION OR WEBSITE IS REFERRED TO IN THIS WORK AS A CITATION AND/OR A POTENTIAL SOURCE OF FURTHER INFORMATION DOES NOT MEAN THAT THE AUTHOR OR THE PUBLISHER ENDORSES THE INFORMATION THE ORGANIZATION OR WEBSITE MAY PROVIDE OR RECOMMENDATIONS IT MAY MAKE. FURTHER, READERS SHOULD BE AWARE THAT INTERNET WEBSITES LISTED IN THIS WORK MAY HAVE CHANGED OR DISAPPEARED BETWEEN WHEN THIS WORK WAS WRITTEN AND WHEN IT IS READ.

For general information on our other products and services, please contact our Customer Care Department within the U.S. at 877-762-2974, outside the U.S. at 317-572-3993, or fax 317-572-4002. For technical support, please visit www.wiley.com/techsupport.

Wiley publishes in a variety of print and electronic formats and by print-on-demand. Some material included with standard print versions of this book may not be included in e-books or in print-on-demand. If this book refers to media such as a CD or DVD that is not included in the version you purchased, you may download this material at <http://booksupport.wiley.com>. For more information about Wiley products, visit www.wiley.com.

Library of Congress Control Number: 2013952422

ISBN 978-1-118-66075-1 (pbk); ISBN 978-1-118-66077-5 (ebk); ISBN 978-1-118-66068-3 (ebk)

Manufactured in the United States of America

10 9 8 7 6 5 4 3 2 1

Contents at a Glance

.....

<i>Introduction</i>	1
<i>Part I: Getting Started with 3D Printing</i>	7
Chapter 1: Seeing How 3D Printers Fit into Modern Manufacturing	9
Chapter 2: Exploring the Types of 3D Printing	23
Chapter 3: Exploring Applications of 3D Printing.....	41
<i>Part II: Outlining 3D Printing Resources</i>	61
Chapter 4: Identifying Available Materials for 3D Printing.....	63
Chapter 5: Identifying Sources for 3D-Printable Objects	81
<i>Part III: Exploring the Business Side of 3D Printing.....</i>	99
Chapter 6: Commoditizing 3D Printing	101
Chapter 7: Understanding 3D Printing's Effect on Traditional Lines of Business	117
Chapter 8: Reviewing 3D Printing Research.....	131
<i>Part IV: Employing Personal 3D Printing Devices</i>	143
Chapter 9: Exploring 3D-Printed Artwork.....	145
Chapter 10: Considering Consumer-Level 3D Printers.....	157
Chapter 11: Deciding on a RepRap of Your Own	169
<i>Part V: Creating a RepRap 3D Printer</i>	199
Chapter 12: Assembling Structural Elements.....	201
Chapter 13: Understanding RepRap Control Electronics	231
Chapter 14: Assembling the RepRap Extruder and RepRap Upgrades.....	265
Chapter 15: Identifying Software and Calibrating Your 3D Printer	295
<i>Part VI: The Part of Tens</i>	331
Chapter 16: Ten Ways That Rapid Prototyping Will Disrupt Traditional Manufacturing.....	333
Chapter 17: Ten Examples of Direct-Digital Manufacturing and Personalization	339
Chapter 18: Ten Impossible Designs Created Using Additive Manufacturing	345
<i>Index</i>	349

Table of Contents

<i>Introduction</i>	1
About This Book	1
Foolish Assumptions	2
Icons Used in This Book.....	2
How This Book Is Organized	3
Part I: Getting Started with 3D Printing.....	3
Part II: Outlining 3D Printing Resources	3
Part III: Exploring the Business Side of 3D Printing.....	3
Part IV: Employing Personal 3D Printing Devices.....	4
Part V: Creating a RepRap 3D Printer.....	4
Part VI: Parts of Tens.....	4
Beyond the Book.....	4
Where to Go from Here	5
<i>Part I: Getting Started with 3D Printing</i>	7
Chapter 1: Seeing How 3D Printers Fit into Modern Manufacturing	9
Embracing Additive Manufacturing.....	10
Defining additive manufacturing	11
Contrasting traditional manufacturing	12
Understanding the advantages of additive manufacturing	16
Exploring the Applications of 3D Printing	20
Working with RepRap.....	21
Chapter 2: Exploring the Types of 3D Printing	23
Exploring Basic Forms of Additive Manufacturing.....	24
Photopolymer	25
Granular	28
Lamination.....	31
Fused deposition modeling	33
Recognizing Specialized Forms of Additive Manufacturing	34
Manufacturing with a variety of materials	34
Printing in color	35
Seeing the Limitations of Current Technologies.....	37
Considering fabrication rates.....	37
Exploring size constraints	38
Identifying object design constraints.....	39
Understanding material restrictions	39
Chapter 3: Exploring Applications of 3D Printing	41
Creating Objects Directly Using 3D Printing Today	42
Rapid prototyping.....	42
Direct digital fabrication.....	44
Restoration and repair.....	45

Fabricating Tomorrow Using 3D Printing	47
Household goods	48
Buildings	49
Extreme recycling	51
Examining Molding and Casting through 3D Printing	52
Lost-material casting.....	53
Sintered metal infusion	53
Applying Artistic Touches and Personalization	53
Medical implants.....	54
Item personalization.....	55
Clothing and textiles	56
Deploying Technology to Strategic Locations	58
Military fabrication.....	58
In space.....	59

Part II: Outlining 3D Printing Resources..... 61

Chapter 4: Identifying Available Materials for 3D Printing 63

Enumerating Extruded Materials	64
Thermoplastics	64
Experimental materials	69
Extruded alternatives.....	69
Identifying Granular Materials	70
Plastic powders.....	71
Sugar and salt.....	71
Metal powders.....	73
Sand and natural granular materials.....	73
Exploring Photo-Cured Resins	74
Understanding Bioprinting	74
Bioprinting food and animal products.....	76
Replacement tissues and organs.....	76
Identifying Alternative Materials	77
Recycled materials	77
Storing food.....	79
Caring for people	79

Chapter 5: Identifying Sources for 3D-Printable Objects 81

Exploring Object Repositories	82
Vendor repositories	82
Community repositories.....	84
Designing in the Computer	85
Scanning Objects.....	88
Capturing Structure from Photographs	92
Preparing Models for Printing.....	94
3D model viewers	96
Mesh modelers.....	97
Mesh repairers.....	97

***Part III: Exploring the Business Side of 3D Printing* 99**
Chapter 6: Commoditizing 3D Printing 101

Democratizing Manufacturing	101
Derived designs	102
Curated artifacts	102
Creating models	103
Crafting Personal Storefronts	106
Creating a unique design	107
Fabricating a unique product on demand	109
Creating Impossible Objects	111
Building New Tools	112
Moving beyond solid blocks	112
Creating the tool that will create the tool	114

Chapter 7: Understanding 3D Printing's Effect on Traditional Lines of Business 117

Transforming Production	117
Displacing the production line	118
Abbreviating the manufacturing chain	120
Providing local fabrication	121
Eliminating traditional release cycles	122
Challenging Intellectual Property Laws	122
Threatening IP protections	123
Assigning legal liability	125
Leveraging Expired Patents	126
Innovating around intellectual property	127
Protecting intellectual property rights	128
Imposing Ethical Controls	129

Chapter 8: Reviewing 3D Printing Research 131

Building Fundamental Technologies	131
Crafting educational tools	132
Expanding 3D printing options	133
3D-printed electronics	134
Creating Functional Designs	135
Drones, robots, and military applications	136
Von Neumann machines	136
Expanding Material Selection	137
Providing for Long Space Voyages	138
Creating Medical Opportunities	140

***Part IV: Employing Personal 3D Printing Devices* 143**
Chapter 9: Exploring 3D-Printed Artwork 145

Adorning the Body	145
Personalizing Our Environment	147
Returning to Personal Creation	148
Visualizing the Abstract	151

Chapter 10: Considering Consumer-Level 3D Printers	157
Examining Cartesian 3D Printers	158
Exploring Delta Options	161
Understanding Polar Fabrication	164
Building Emerging Alternatives	166
Chapter 11: Deciding on a RepRap of Your Own	169
Evaluating Your 3D-Printing Needs	169
Do I want a RepRap or another 3D printer?	170
Do I buy a ready-built 3D printer or use a kit?	171
Open, Closed, and Licensing	172
Selecting a 3D Printer Design	175
RepRap designs	175
Home 3D-printer kits	179
The experimental designs	182
Further machine arrangements	184
Choosing Print Media	184
Thermoplastic	184
PLA / PHA plastic	185
ABS	189
Paste	189
Identifying Components	190
Structural framework	191
The extruder	191
Build plate	194
Control electronics	195
Software	196

Part V: Creating a RepRap 3D Printer **199**

Chapter 12: Assembling Structural Elements	201
Locating Materials	201
Kits	202
Self-sourcing	204
Printing your own	204
eBay	205
Obtaining the Printed Parts for Machine Assembly	205
Understanding the Machine Motion	207
Z-axis motion	208
X and Y axis motion	210
Building the Frame Structure	212
Assembling the Prusa i3 Y Axis Frame	217
Assembling the Moving Axis	218
Assembling the Prusa i3 moving Y axis	221
Assembling the Prusa i3 moving Z and X axes	223
Joining the Z, X and Y axis all together	227
Sensing the Home Position	227

Chapter 13: Understanding RepRap Control Electronics	231
Overview of RepRap Electronics.....	231
RAMPS	232
RAMBo.....	233
Sanguinololu.....	233
Minitronics	234
RUMBA	234
Elefu-RA V3	235
Megatronics.....	237
Adding Electronics to Your RepRap 3D Printer.....	238
Preparing for electronics assembly	238
Modular Components, Sensors, and Motors.....	245
Computer-free printing	245
Using motor-driver modules	246
Selecting your position sensing modules	248
Identifying power-supply requirements	250
Adding fans and lighting	252
RepRap Wiring and Connections	254
Firmware Configuration	256
Prusa i3 firmware configuration	256
Uploading the Marlin firmware to the RAMPS electronics.....	262
Chapter 14: Assembling the RepRap Extruder and RepRap Upgrades.	265
Thermoplastic Extrusion	265
Prusa i3 Extruder and Hot-End Assembly.....	272
Fitting the filament drive to the motor shaft.....	273
Assembling the extruder idler pressure bearing.....	273
Fitting the J-head hot-end	274
Syringe and Paste-Based Extrusion	275
Multi-Color Printing	279
Extruder Operation and Upgrades	285
Fixing a blocked hot-end or extruder	287
Acquiring an assortment of extruders	289
Cooling extruders with fans	291
Chapter 15: Identifying Software and Calibrating Your 3D Printer.	295
3D Design Software and Model Resources	295
Using design software	301
Model verification with Netfabb	303
Working with Slic3r.....	304
Configuring Slic3r	304
Model processing with Slic3r	307
Calibrating Your 3D Printer	314
Leveling your print bed.....	316
Tuning your hot-end temperature control	318
Extruder distance calibration	318
3D-Printing Objects.....	322
Printing vases, pots, and cups	325
Printing large single-piece objects	328



Printing tiny or highly detailed objects328
Printing many objects at once329
Improving print quality329

Part VI: The Part of Tens..... 331

Chapter 16: Ten Ways That Rapid Prototyping Will Disrupt Traditional Manufacturing 333

Reducing Time to Market.....333
Eliminating Mass Manufacturing.....334
Displacing Transportation Industries334
Consuming Alternate Materials.....335
Reducing Material Requirements.....335
Going Green335
Curtailing Planned Obsolescence336
Eliminating One-Size-Fits-Most336
Crafting What You Wish.....337
Providing Basic Necessities.....338

Chapter 17: Ten Examples of Direct-Digital Manufacturing and Personalization 339

Producing 3D-Printed Food339
Printing Tissues and Organs340
Fashioning Biological Replicas340
Crafting Clothing and Footwear340
Customizing Artwork.....341
Making Hollywood Spectacular.....342
Creating Structures.....342
Reaching Beyond the Sky.....342
Constructing Robots.....343
Printing 3D Printers343

Chapter 18: Ten Impossible Designs Created Using Additive Manufacturing 345

Personalized Objects.....345
Medical Implants.....345
Self-Deploying Robots346
Printed Aircraft347
On-Demand, On-Site Manufacturing347
Custom Objects Created in Space347
Printed Finger Foods347
Locally Fabricated Items348
Body Parts.....348
Custom Drugs348

Index..... 349

Introduction

.....

Unlike traditional manufacturing which involves injecting material into a pre-formed mold or removing material from base material objects, additive manufacturing (3D printing) starts with a virtual 3D model that is transformed into solid form one layer at a time. Each layer is built on top of the layer before, creating a solid form representing the virtual 3D model in all of its complexity and detail without requiring additional forms of machining and treatment necessary in traditional forms of manufacturing.

Although 3D printers have been available for years, only recently have they become available at a price most home users can afford. Because they are becoming more widespread, and because innovations in this technology now permit the creation of products in a much wider array of materials — and even combinations of materials — 3D printing is poised to make an impact on average consumers in a big way. *3D Printing For Dummies* was written with the average reader in mind. It's a survey of the existing capabilities of additive manufacturing, for both private and commercial purposes, and a consideration of the possibilities of its future.

About This Book

In this book, we review many different technologies currently available for additive manufacturing. These are early-generation technologies with numerous limitations and caveats to their use and the selection of materials available for use in 3D printers in both commercial-scale and consumer-grade options. We also explore the process by which you can build your own 3D printer using the open-source self-REplicating RAPid-prototyping (RepRap) family of designs. This will not make you an expert in all aspects of 3D printing, but will provide you with an opportunity to explore the many types of additive manufacturing systems. Hopefully, you will be excited by the amazing potential of 3D printers – excited enough to build your own printer and start sharing your own creativity with friends and family!

Foolish Assumptions

You might find it difficult to believe that we have assumed anything about you — after all, we haven't even met you yet! Although most assumptions are indeed foolish, I made these assumptions to provide a starting point for the book.

It is important to understand that the current level of sophistication in 3D printers is close to the first automated looms that found their way into factory settings in the early 1700's. Commercial 3D printers have less variance, but for consumer-grade equipment a certain amount of "tinkering" will be needed from time to time to keep things running. Working with 3D printers is very rewarding, but you should learn how to adjust and tune your home or office printer so that when things go awry you will be able to fix them yourself. It is not necessary to be a do-it-yourself handyman, but a certain familiarity with basic tools will help you when you build, assemble, or use your own 3D printer.

The book assumes you will have the ability to download or access programs in a web browser if you want to try out some of the applications we review, such as TinkerCAD. However, it is not necessary to have a computer of your own to enjoy this book — all you need is an open mind and enthusiasm about the future and what additive manufacturing can produce!

Icons Used in This Book

As you read this book, you'll see icons in the margins that indicate material of interest (or not, as the case may be). This section briefly describes each icon in this book.



Tips are nice because they help you save time or perform some task without a lot of extra work. The tips in this book give you timesaving techniques or pointers to resources that you should check out to get the maximum benefit from 3D printing.



I don't want to sound like an angry parent or some kind of maniac, but you should avoid doing anything marked with a Warning icon.



Whenever you see this icon, think *advanced* tip or technique. You might find these tidbits of useful information just too boring for words, or they could contain the solution you need. Skip these bits of information whenever you like.



If you don't get anything else out of a particular chapter or section, remember the material marked by this icon. This text usually contains an essential process or a bit of information that you must know.

How This Book Is Organized

We divide this book into several parts based on topic. The following sections describe what you can expect to find in each part.

Part I: Getting Started with 3D Printing

Part I explores fundamental 3D printing technologies and options for additive manufacturing within the current state of the art. It is intended to provide you with a general overview of what additive manufacturing provides today.

Part II: Outlining 3D Printing Resources

Part II expands your exploration of additive manufacturing to include different materials that can be used in current and near-future 3D printing technologies, and examines options available to create new virtual 3D object models to be printed.

Part III: Exploring the Business Side of 3D Printing

Part III examines the potential for disruption in existing businesses and new business opportunities that becomes possible through new additive manufacturing capabilities. We also explore current lines of research, building new options to the current state of the art.

Part IV: Employing Personal 3D Printing Devices

Part IV explores consumer-level 3D printer options including both commercial and open-source alternatives available for home and small business uses in fabricating creative and artistic designs exploring this magnificent new capability. We discuss considerations you should take into account when building your own RepRap-style 3D printer.

Part V: Creating a RepRap 3D Printer

Part V walks you through the creation, assembly, and calibration of a RepRap style printer.

Part VI: Part of Tens

Part VI offers lists of ten interesting, disruptive, or impossible (in traditional manufacturing) applications of additive manufacturing.

Beyond the Book

A lot of extra content that you won't find in this book is available at www.dummies.com. Go online to find the following:

✔ **Online articles covering additional topics at**

www.dummies.com/extras/3dprinting

Here you'll find examples of how to use available software to design and prepare 3D models for printing and to set up your own personal digital storefront using free services already in place.

✔ **The Cheat Sheet for this book is at**

www.dummies.com/cheatsheet/3dprinting

Here you'll find a roadmap to additive manufacturing and the construction of your own RepRap-style 3D printer.

✔ **Updates to this book, if we have any, are also available at**

www.dummies.com/extras/3dprinting

Where to Go from Here

The goal of this book is to get you thinking about 3D printing and the potential it offers in your own life, home, or work. We stand at the start of a new Industrial Age, where traditional mass manufacturing will give way to personalized, individualized, ecologically-friendly and on-demand manufacturing close to home. You do not have to read this book cover-to-cover, although I think you will find interesting and amazing items on each page. In any event, we hope you walk away with dozens of ideas for improvements, uses and new capabilities made possible by the emerging capabilities of 3D printers.

Part I

Getting Started with 3D Printing



Visit www.dummies.com for great Dummies content online.

In this part...

- ✓ Explore the world of 3D printing, including many of the different types of additive manufacturing and their applications.
- ✓ Discover current uses for the ever-growing spectrum of 3D-printing alternatives available today.
- ✓ Examine alternatives currently in existence for 3D printing.
- ✓ Discover ways that you may be able to use additive manufacturing in personal and professional settings.

Chapter 1

Seeing How 3D Printers Fit into Modern Manufacturing

.....

In This Chapter

- ▶ Embracing additive manufacturing
 - ▶ Defining additive manufacturing
 - ▶ Contrasting traditional manufacturing
 - ▶ Recycling and planned obsolescence
 - ▶ Exploring the application of 3D printing
-

An amazing transformation is currently under way in manufacturing, across nearly all types of products — a transformation that promises to remake the future into a sustainable and personally customized environment. In this fast-approaching future, everything we need — from products to food, and even our bodies themselves — can be replaced or reconstructed rapidly and with very minimal waste. This is not the slow change of progress from one generation of iPhone to the next, but instead a true revolution, mirroring the changes that introduced the world to the Industrial Age and then brought light and electricity to our homes and businesses.

This will not be a “bloodless coup” by any means; any truly fundamental change that spans all aspects of the global economy will, by its nature, be disruptive. But traditional inefficient ways of producing the next year’s model will surely give way to entirely new opportunities impossible to imagine before. The technology behind this transformation is referred to as *additive manufacturing*, *3D printing*, or *direct digital manufacturing*.

By whatever name, in the coming decade this technology will be used to construct everything from houses to jet engines, airplanes, food, and even replacement tissues and organs made from your own cells! Every day new applications of 3D printing are being discovered and developed all over the world. And even in space: NASA is testing designs that will function in zero gravity, on the airless moon, and even to support human exploration of

other planets like Mars. (See Figure 1-1 for a glimpse.) Hold on tight, because in the chapters ahead we cover a lot of incredibly new and fantastic technologies — and before the end, we show you how you can get involved in this amazing transformation yourself by building and using a 3D printer at home.

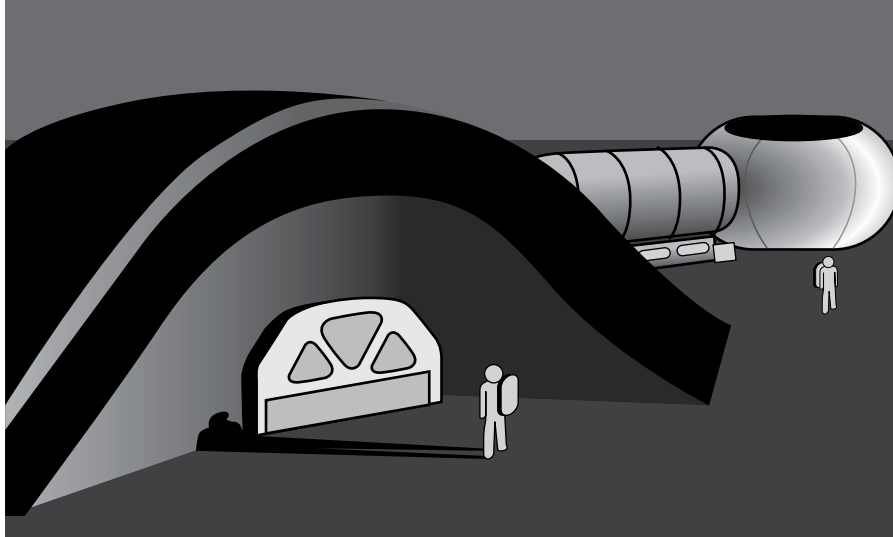

Figure 1-1: A line drawing of NASA's planned 3D-printed lunar construction.

Embracing Additive Manufacturing

So, what is “additive manufacturing,” you might ask? Additive manufacturing is a little like the “replicators” in the *Star Trek* universe, which allow the captain to order “Tea, Earl Grey, hot” and have a cup filled with liquid appear fully formed and ready for consumption. We are not quite to that level, but today’s 3D printers perform additive manufacturing by taking a 3D model of an object stored in a computer, translating it into a series of very thin layers, and then building the object one layer at a time, stacking up material until the object is ready for use.



3D printers are much like the familiar desktop printer you already use at work or in your home to create copies of documents transmitted electronically or created on your computer, except that a 3D printer creates a solid three-dimensional object out of a variety of materials, not just a simple paper document.

Since the time of Johannes Gutenberg, creating multiple printed documents has brought literacy to the world. Today, when you click the Print button in a word processor application, you merge the functions of writers,

stenographers, editors (spellcheck), layout, illumination (coloring and adding in images), and press reproduction all into a single task, and with the click of a few more buttons, you can post the document you create onto the Internet and allow it to be shared, downloaded, and printed out by others all over the world.

3D printing does the exact same thing for objects: Designs and virtual 3D models for physical objects can be shared, downloaded, and then printed out into physical form. It's hard to imagine what Johannes Gutenberg would have made of that.

Defining additive manufacturing

Why is additive manufacturing called “additive?” Additive manufacturing works by bringing the design of an object — its shape — into a computer model, then dividing that model into separate layers that can stack atop another to form the final object. It reimagines a three-dimensional object as a series of stackable layers that, when added together, forms the finished object. (See Figure 1-2.) Whether this object is a tea cup or a house, the process starts with the base layer and then builds up each additional layer until the full object has been completed.

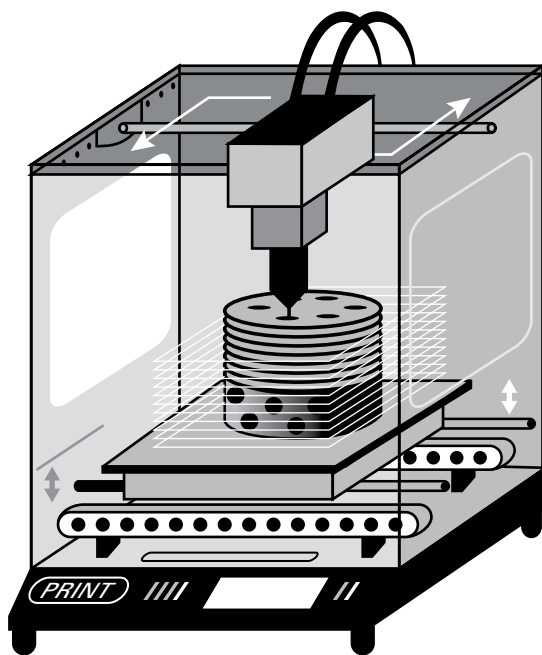

Figure 1-2:
A line drawing of how 3D printing works.

My children did this before they ever saw my first 3D printer. They discovered they could use crackers and cheese spray for more than just a snack — they could build towers and grand designs simply by layering crackers and cheese on top of each other. These edible structures show the potential in additive manufacturing. Each cracker was given a personalized application of cheese to spell out names, draw designs, and even to build shapes and support tiny pyramids. The resulting snacks were both unique and also customized to exactly the design each child wanted.

3D printers build up layers of material in a few different ways: Either they fuse liquid polymers with a laser, bind small granular particles using a laser or a liquid binding material, or they extrude melted materials out like a tube of toothpaste squeezed onto a toothbrush. However, 3D printers perform their additive manufacturing using many more materials than just toothpaste or cheese spray. They can fabricate items using photo-curable plastic polymers, melted plastic filament, metal powders, concrete, and many other types of material — including biological cells that can form amazingly complex structures to replace, repair, and even augment our own bodies.

Just as the rings of a tree show the additive layers of growth to the tree each year, additive manufacturing builds up objects one layer at a time. In this way we can create a small plastic toy, a whole car, and very soon an entire house (with all of its furnishings), or even complete airplanes with interlocking parts. Research today on conductive materials suggests that wires will soon become just another part of the additive manufacturing process, by allowing them to be printed directly into an object itself instead of having to be installed later.

Contrasting traditional manufacturing

How does this additive manufacturing compare to the traditional methods of production that have worked just fine since the First Industrial Revolution in the 1700's transformed manufacturing from hand production to automated production, using water and steam to drive machine tools? Why do we need to take up another disruptive technological shift after the Second Industrial Revolution in the 1800's transformed the world through the increased use of steam-powered vehicles and the factories that made mass manufacturing possible? Today, we stand at the opening moment of the next transformation, a Third Industrial Revolution, where mass manufacturing and global transfer of bulk goods will be set aside in favor of locally-produced and highly personalized individual production fitting society's transition to a truly global phase of continuous self-upgrade and incremental local innovation.

The First Industrial Revolution's disruption of society was so fundamental that governments had to pass laws to protect domestic wool textile production in England against new power-woven cotton textiles being imported

- [7th Sigma for free](#)
- [click The Dark Side Of The Screen: Film Noir book](#)
- [Texas Storm \(Executioner, Book 18\) pdf, azw \(kindle\), epub](#)
- [**William Shakespeare: The Critical Heritage Volume 2 1693-1733 \(The Collected Critical Heritage : William Shakespeare\) pdf, azw \(kindle\), epub**](#)
- [download online Kitchen Science Lab for Kids: 52 Family Friendly Experiments from the Pantry here](#)
- [Dead Man Rising.pdf](#)

- <http://tuscalaural.com/library/7th-Sigma.pdf>
- <http://nautickim.es/books/The-Dark-Side-Of-The-Screen--Film-Noir.pdf>
- <http://aneventshop.com/ebooks/His-Brother-s-Bride--Banks-Brothers--Brides--Book-4-.pdf>
- <http://creativebeard.ru/freebooks/The-History-of-Montr--al--The-Story-of-a-Great-North-American-City.pdf>
- <http://yachtwebsitedemo.com/books/Not-Just-a-Witch.pdf>
- <http://metromekanik.com/ebooks/Who-I-Am-and-What-I-Want.pdf>