

Two-Stroke Engine Repair & Maintenance

Two-Stroke Engine Repair & Maintenance

Paul Dempsey



New York Chicago San Francisco Lisbon London Madrid
Mexico City Milan New Delhi San Juan Seoul
Singapore Sydney Toronto

Copyright © 2010 by The McGraw-Hill Companies, Inc. All rights reserved. Except as permitted under the United States Copyright Act of 1976, no part of this publication may be reproduced or distributed in any form or by any means, or stored in a data base or retrieval system, without the prior written permission of the publisher.

ISBN: 978-0-07-162540-1

MHID: 0-07-162540-2

The material in this eBook also appears in the print version of this title: ISBN: 978-0-07-162539-5, MHID: 0-07-162539-9.

All trademarks are trademarks of their respective owners. Rather than put a trademark symbol after every occurrence of a trademarked name, we use names in an editorial fashion only, and to the benefit of the trademark owner, with no intention of infringement of the trademark. Where such designations appear in this book, they have been printed with initial caps.

McGraw-Hill eBooks are available at special quantity discounts to use as premiums and sales promotions, or for use in corporate training programs. To contact a representative please e-mail us at bulksales@mcgraw-hill.com.

Information contained in this work has been obtained by The McGraw-Hill Companies, Inc. (“McGraw-Hill”) from sources believed to be reliable. However, neither McGraw-Hill nor its authors guarantee the accuracy or completeness of any information published herein, and neither McGraw-Hill nor its authors shall be responsible for any errors, omissions, or damages arising out of use of the information. This work is published with the understanding that McGraw-Hill and its authors are supplying information but are not attempting to render engineering or other professional services. If such services are required, the assistance of an appropriate professional should be sought.

TERMS OF USE

This is a copyrighted work and The McGraw-Hill Companies, Inc. (“McGraw-Hill”) and its licensors reserve all rights in and to the work. Use of this work is subject to these terms. Except as permitted under the Copyright Act of 1976 and the right to store and retrieve one copy of the work, you may not decompile, disassemble, reverse engineer, reproduce, modify, create derivative works based upon, transmit, distribute, disseminate, sell, publish or sublicense the work or any part of it without McGraw-Hill’s prior consent. You may use the work for your own noncommercial and personal use; any other use of the work is strictly prohibited. Your right to use the work may be terminated if you fail to comply with these terms.

THE WORK IS PROVIDED “AS IS.” MCGRAW-HILL AND ITS LICENSORS MAKE NO GUARANTEES OR WARRANTIES AS TO THE ACCURACY, ADEQUACY OR COMPLETENESS OF OR RESULTS TO BE OBTAINED FROM USING THE WORK, INCLUDING ANY INFORMATION THAT CAN BE ACCESSED THROUGH THE WORK VIA HYPERLINK OR OTHERWISE, AND EXPRESSLY DISCLAIM ANY WARRANTY, EXPRESS OR IMPLIED, INCLUDING BUT NOT LIMITED TO IMPLIED WARRANTIES OF MERCHANTABILITY OR FITNESS FOR A PARTICULAR PURPOSE. McGraw-Hill and its licensors do not warrant or guarantee that the functions contained in the work will meet your requirements or that its operation will be uninterrupted or error free. Neither McGraw-Hill nor its licensors shall be liable to you or anyone else for any inaccuracy, error or omission, regardless of cause, in the work or for any damage

resulting therefrom. McGraw-Hill has no responsibility for the content of any information accessed through the work. Under no circumstances shall McGraw-Hill and/or its licensors be liable for any indirect, incidental, special, punitive, consequential or similar damages that result from the use of or inability to use the work, even if any of them has been advised of the possibility of such damages. This limitation of liability shall apply to any claim or cause whatsoever whether such claim or cause arises in contract, tort or otherwise.

About the Author

Paul Dempsey is a master mechanic, and former editor of *World Oil* magazine. He is the author of more than 20 technical books, including *Small Gas Engine Repair*, *How to Repair Briggs & Stratton Engines*, and *Troubleshooting and Repairing Diesel Engines*.

Contents

Introduction

1 • Fundamentals

[Two-cycle operation](#)

[Displacement](#)

[Compression ratio](#)

[Torque and horsepower](#)

[Premix](#)

[Cooling](#)

[Emissions](#)

[The four-cycle option](#)

[Cleaner two-cycle exhaust](#)

[Marks of quality](#)

[The learning curve](#)

[Long-term storage](#)

[Safety](#)

[Recalls](#)

[Conclusion](#)

2 • Troubleshooting

[Things to keep in mind](#)

[Tools and supplies](#)

[Preliminaries](#)

[Tests](#)

[Complaints](#)

3 • Ignition systems

[Diagnosis](#)

[Flywheel](#)

[E-gap](#)

[Magnetos](#)

[Spark plugs](#)

[Summary](#)

4 • Fuel systems

[Fuel tank](#)

[Fuel filters](#)

[Fuel lines](#)

[Air filters](#)

[Carburetors](#)

[A last word](#)

5 • Starters and related components

[Troubleshooting](#)

[Overview](#)

[Clutch-type starters](#)

[Ratchet drive](#)

[Things to remember](#)

6 • Engine service

[Tests](#)

[Overview](#)

[Fasteners](#)

[Adhesives and sealants](#)

[Philosophy](#)

[Housekeeping](#)

[Cylinder head](#)

[Rings and piston](#)

[Cylinder bores](#)

[Lower end](#)

[Now that the hard part is done](#)

7 • Power transmission

[Centrifugal clutches](#)

[V-belts](#)

[Belt-driven torque converter](#)

[Drive chains](#)

[Sprockets](#)

[Geared drives](#)

[Friction drive](#)

[Sign off](#)

[Index](#)

Introduction

As two-strokes fire every revolution, they are the most powerful engines for their size known. Highly tuned examples develop nearly two hp per cubic inch of displacement and run happily at 11,000-plus rpm. And with only three basic moving parts, two-strokes are the simplest and least expensive form of internal combustion.

Yet, for many owners these little engines are contrivances from hell, cantankerous, difficult to start, and impossible to fix. Drive by a suburban neighborhood on trash collection day and you will find edgers, weed trimmers, and Chinese mini-bikes awaiting pickup at the curbside. The very simplicity of the two-stroke principle makes it unforgiving.

Actually, these engines are easy to live with, if you have the background information and the tools to make a few simple diagnostic tests. And once past the fear of getting their hands dirty, most people find that fixing things is rewarding. Certainly it is more rewarding than spending \$85 an hour (the current big-city shop rate) for someone else to do the work. Nor can we continue to discard products that no longer function as they should. That phase of American experience is behind us.

The philosophy of this book was inspired by a lady who visited our class as a substitute teacher long these many years ago. She was the daughter of a Spanish ambassador to the United States and, during the Second World War, had volunteered to teach Latin American pilots to ferry aircraft across the Atlantic. Although her students were trained pilots, they had not qualified on the large, multi-engine aircraft they would be flying. The students spoke five languages, none of which was English. Flight manuals, written in English, were useless. The lady, whose name I unfortunately cannot recall, realized that her only hope was to simplify instruction. Rather than translate the recipe-book format of manuals, she explained the physics of cockpit instrumentation, how the readings related to the forces acting on aircraft. That sort of knowledge, which cuts to the heart of things, was translatable and memorable. She did not lose a single pilot.

I have tried to do something similar here by stressing how the various components that make up an engine function. Once you understand the basic principles of, say, carburetion, this knowledge becomes a sort of mental tool box that gives you the leverage to repair any carburetor.

The initial chapter describes how two-stroke engines function and the ways these engines have evolved under the pressure of ever-tightening emissions regulations. Encountering a new technology is like meeting someone for the first time. To achieve understanding, to come into sync, requires an appreciation of the forces that have shaped the person.

An internal combustion engine can be thought of as a collection of four systems—ignition, fuel, starting, and those mechanical parts that generate compression. The troubleshooting chapter shows how to isolate a malfunction to a particular system. Fixing on the right system is the basic diagnostic skill that separates mechanics from parts changers. Once you have identified the system at fault, turn to the appropriate chapter for detailed diagnostic procedures and step-by-step repair instructions.

When factory tools are mentioned, they are illustrated so that substitutes can be found or fabricated. And whenever possible, multiple ways of performing the same task are described. Depending on the tools available, you can remove a flywheel by any of three methods. There are at least four ways to separate crankcase castings and several approaches to tuning carburetors.

You will also find much information here on adhesives, sealants, solvents, nylon cord, lubricating oils, and a host of other products that contribute to long-lasting repairs.

This book has more than 100 illustrations, many of them photographs supplied by my good friend Robert Shelby. STIHL, Tanaka, Dorman, and several other manufacturers were kind enough to allow illustrations from their parts and shop manuals to be used.

Paul Dempsey

Two-Stroke Engine Repair & Maintenance

1

Fundamentals

There comes a time when work stops and the mechanic becomes abstracted, distant from the task at hand. Something about the machine does not conform to the picture in the mechanic's mind. Images flash by until he or she finds one that most closely conforms to actual conditions. Once that is done, repairs can begin.

Constructing visual images is what mechanics do; the other stuff is mere wrench-twisting.

This chapter provides grist for these mental images. Because the material must be conveyed in words, it tends to be abstract. But once you can picture how these engines work, you will have made the first step in the journey to becoming a real mechanic.

Spark-ignition engines operate in a cycle consisting of four events: intake, compression, expansion (or power), and exhaust. A fresh charge of air and fuel is inducted into the cylinder, which then is compressed by the piston and ignited by the spark plug. The pressure created by combustion reacts against the piston to generate torque on the crankshaft. The spent gases then exhaust into the atmosphere.

Four-stroke-cycle engines require four up and down strokes of the piston, or two full crankshaft revolutions, to complete the cycle. Two-stroke-cycle engines telescope events into two strokes or one crankshaft revolution. For convenience we abbreviate the terms to four-cycle or four-stroke, and two-cycle or two-stroke.

Two-cycle operation

Focus on the piston. The double-acting piston works in both directions to compress the air-fuel mixture in the cylinder above it and in the crankcase below it. The piston and connecting rod convert a portion of the heat and energy released by combustion into mechanical motion that turns the crankshaft. Were that not enough, the piston also acts as a slide valve to open and close exhaust, transfer and (in some applications) intake ports. Because it works so hard, the piston is the first mechanical part to fail on two-cycle engines.

Third-port engines

Third-or piston-ported engines have three ports cast or milled into their cylinder liners. The inlet port admits fuel to the crankcase, the transfer port conveys fuel from the crankcase into the combustion chamber, and the exhaust port opens to the atmosphere.

First, let's look at events above the piston during a full turn of the crankshaft. In [Fig. 1-1A](#) the piston approaches the upper limit of travel, or top dead center (TDC), and has compressed the air-fuel mixture above it. The piston has also uncovered the inlet port to admit fuel and air from the carburetor to the crankcase. [Figure 1-1B](#) illustrates the beginning of the power stroke under the impetus of expanding combustion gases. As the piston falls, it first uncovers the exhaust port ([Fig. 1-1C](#)) and, a

few degrees of crankshaft rotation later, the transfer port ([Fig.1-1D](#)). Fuel and air pass through the transfer port and into the cylinder bore.

Meanwhile, much is happening in the crankcase. As the piston falls on the power stroke, it partially fills the crankcase, reducing its volume, as shown in [Fig. 1-1C](#). Since the piston now covers the inlet port, the pressure of the air-fuel mixture trapped in the case rises.

Near bottom dead center (BDC) the piston uncovers the transfer port and the pressurized fuel mixture passes through this port to the upper cylinder ([Fig. 1-1D](#)). The piston then rounds BDC and begins to climb, an action that simultaneously compresses the mixture above the piston and creates a partial vacuum under it. Once the inlet port opens, atmospheric pressure forces fuel and air from the carburetor into the crankcase.

A problem with third-port engines is fuel reversion. At low speeds the crankcase fills to overflowing. When the piston reverses at the top of the stroke, some of the charge can flow back through the inlet port to the carburetor. A fog of oily fuel hovers around the air cleaner, dirtying the engine and playing havoc with carburetor metering.

Reed-valve engines

Although third-port engines are still encountered, many manufacturers prefer to control crankcase filling with a reed valve installed between the carburetor and crankcase. The valve, similar to the reed on musical instruments, opens and closes in response to crankcase pressure ([Fig. 1-2](#)). Utility engines make do with a single reed, or pedal, athwart the intake port ([Fig. 1-3](#)). High-performance engines employ a tent-like valve block with multiple reeds. This arrangement provides a large valve area for better crankcase filling ([Fig. 1-4](#)).

Power stroke

Intake

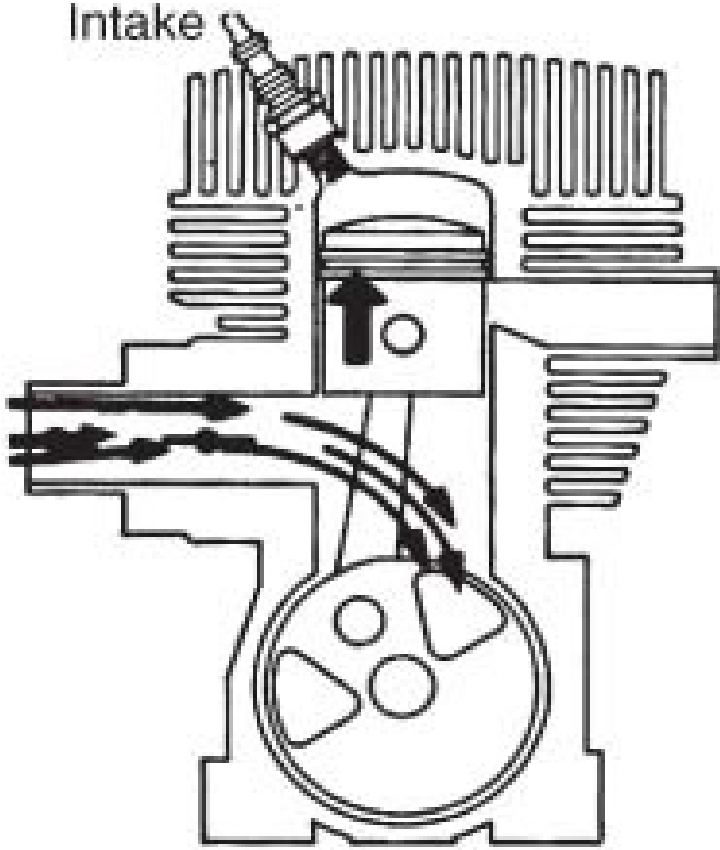

A

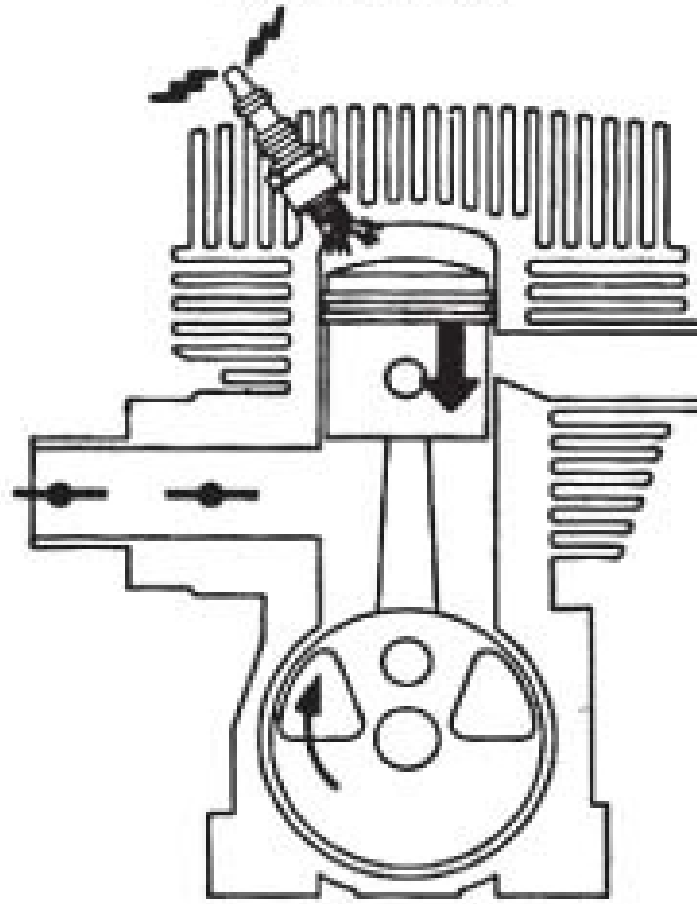

B

Exhaust

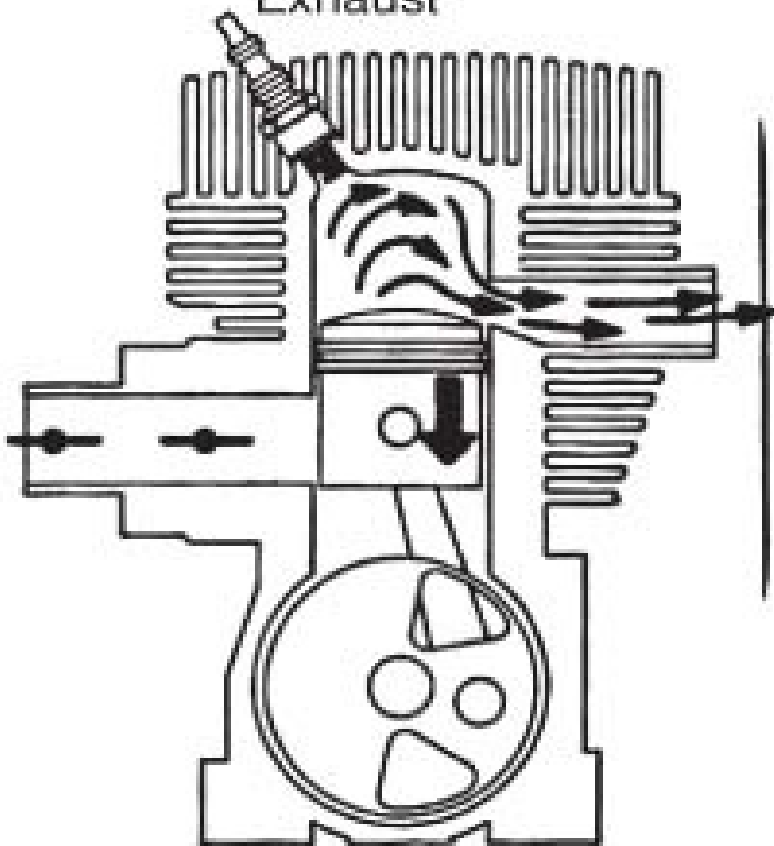

C

Transfer

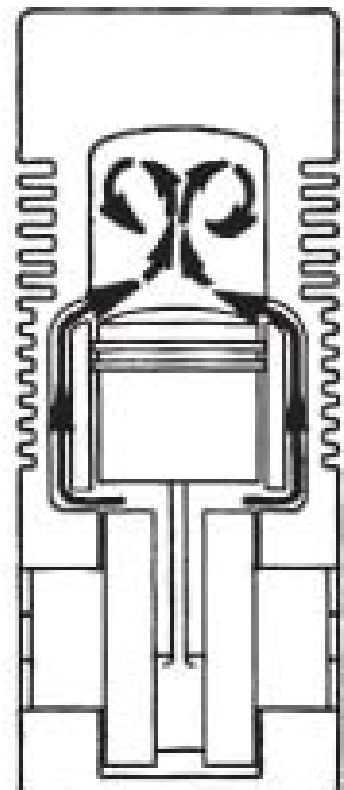

D

Fig. 1-1. Operating sequence of a third-port, loop-scavenged engine. Walbro

For mini-two-strokes, the position of the carburetor indicates the type of inlet valve: when a reed valve is present, the carburetor mounts on the crankcase ([Fig. 1-5](#)). Third-port engines mount their carburetor on the cylinder barrel in line with the inlet port, as shown in [Fig. 1-6](#). Being able to recognize the presence of a reed valve without disassembling the engine is useful, since the reed can malfunction. Should the pedal split or fail to seal, the engine will not start.

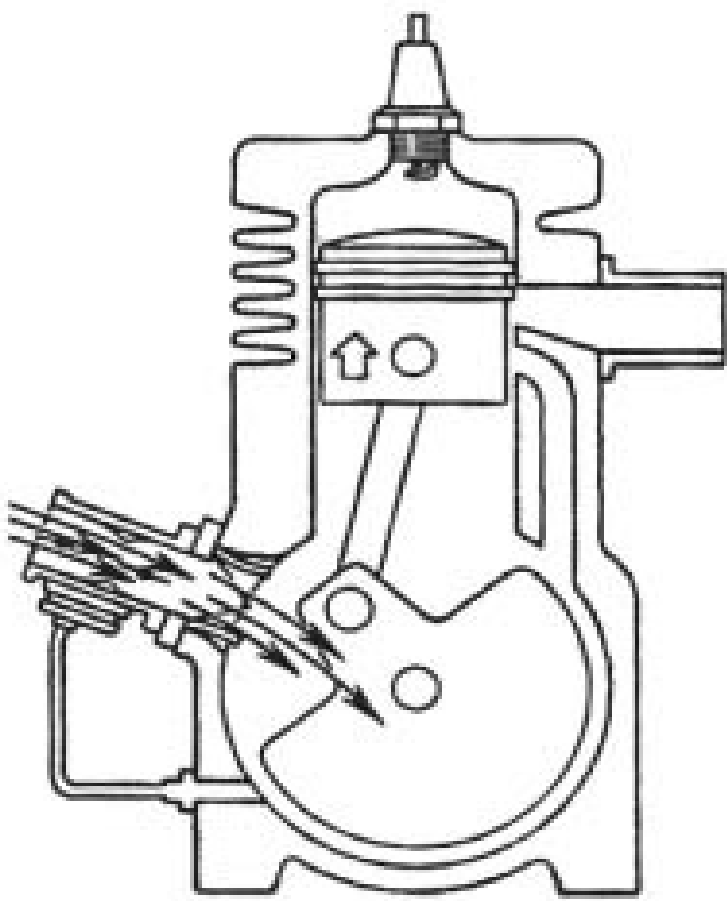

A

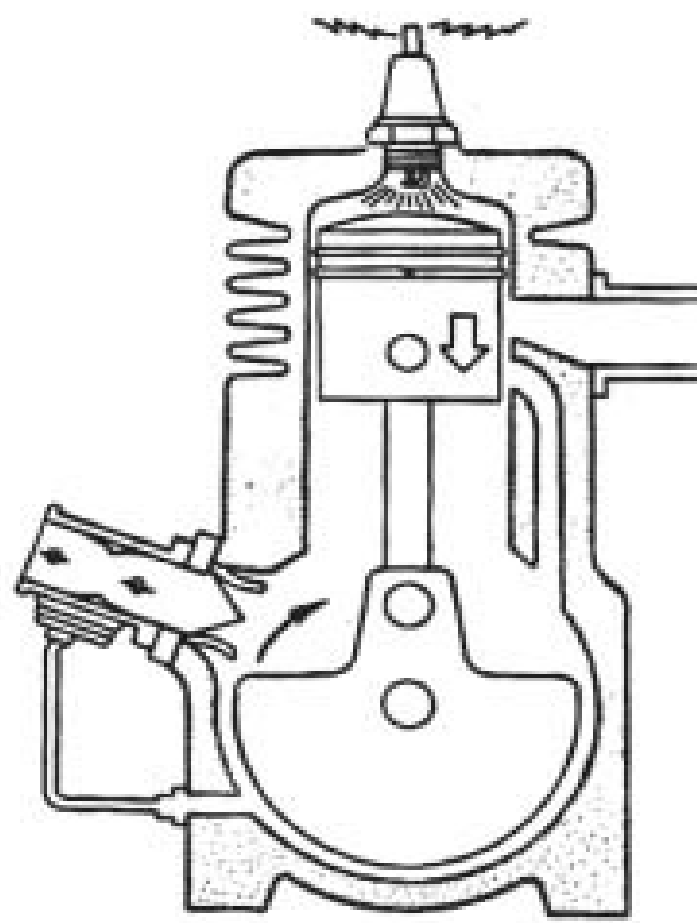

B

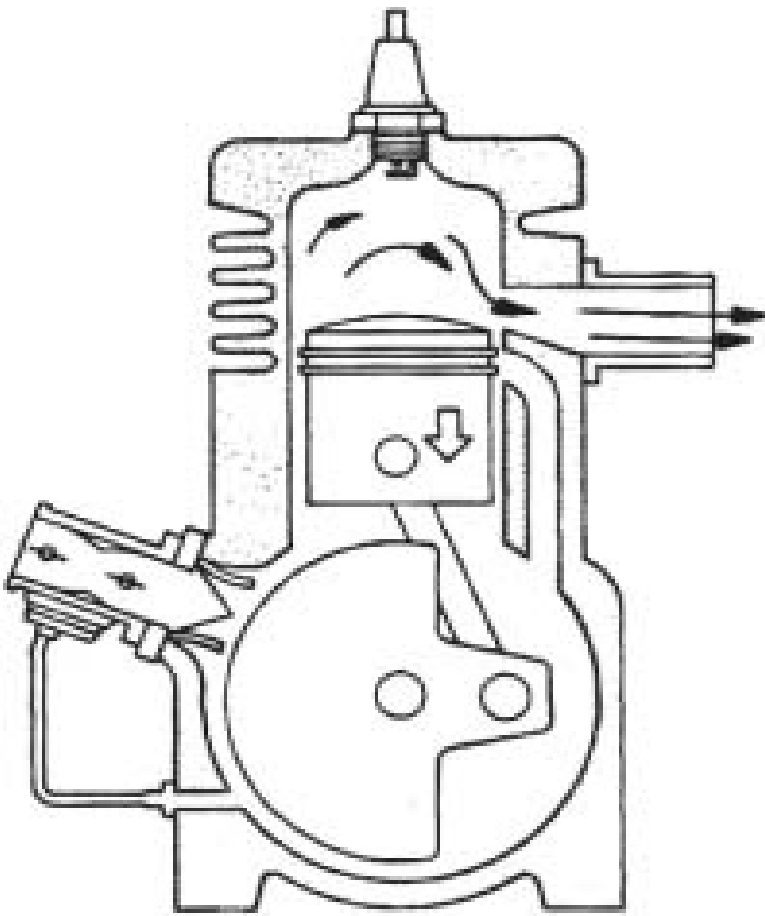

C

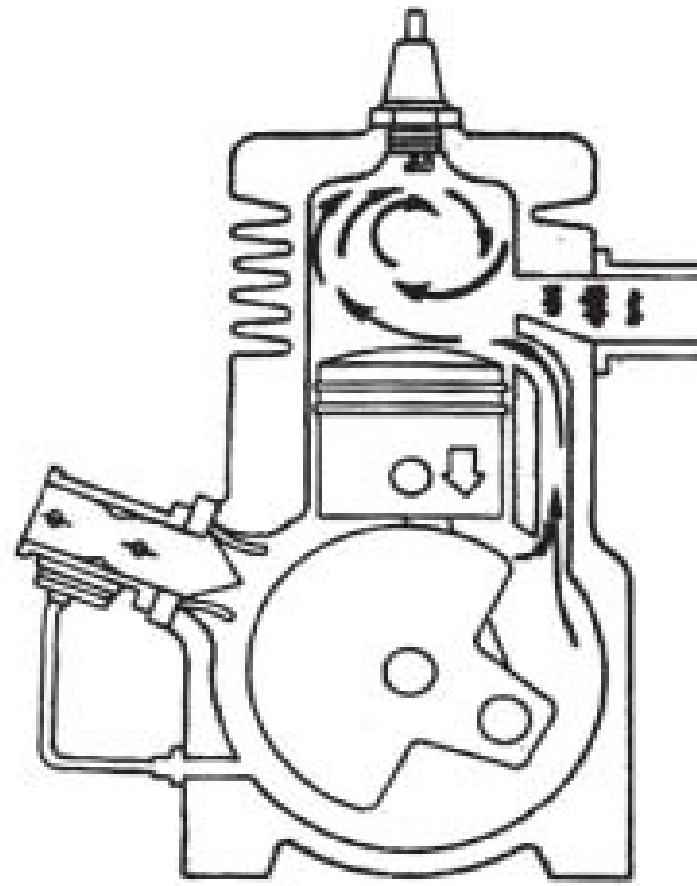

D

Fig. 1-2. *Operating sequence of a reed-valve engine that in the example shown employs loop—scavenging. The small tube on the lower left of the drawing transfers crankcase pressure pulses to the fuel pump. Deere and Company*

But the rule about the carburetor location does not necessarily apply to larger engines. Some European motorcycles had crankcase-mounted carburetors that fed through a rotary valve in the form of a partially cutaway disk, keyed to crankshaft. Model airplane engines and a few vintage outboards use a slotted crankshaft to the same effect.

Motorcycle engines often combine a third port with an integral reed valve. The port controls timing and the reed prevents backflow through the carburetor. Although the reeds impose a pressure drop, midrange torque benefits.



Fig. 1-3. *Reed valves for handheld engines generally have a single pedal backed by a guard plate to limit deflection. Robert Shelby*

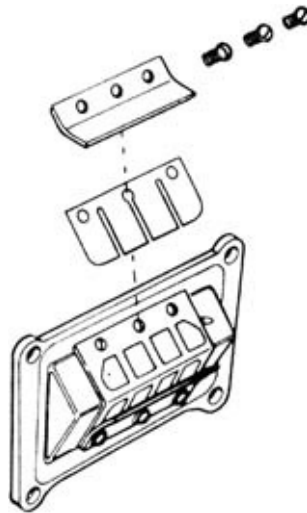

Fig. 1-4. *Multiple pedals are standard on high-performance engines. While there has been considerable experimentation with fiberglass, carbon fiber, and other high-tech materials, spring-steel pedals appear to work as well as any. Tecumseh Products Co.*

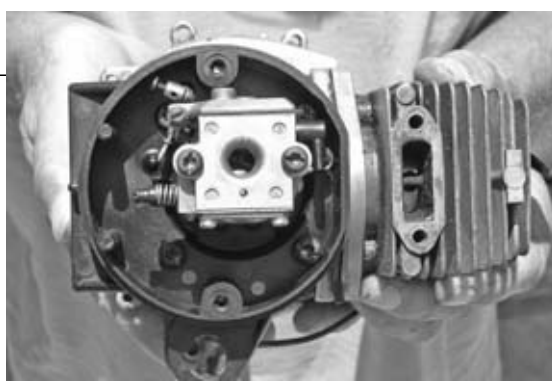

Fig. 1-5. *Reed-valve engines mount their carburetors low on the crankcase.* Robert Shelby



Fig. 1-6. *Carburetors for third-port engines attach to the cylinder. Some of these engines incorporate a reed valve in the third port.* Robert Shelby

Scavenging

Scavenging is the term for purging the cylinder of exhaust gases. Unlike a four-cycle engine, which devotes a full stroke of the piston to clear the cylinder, a two-stroke must scavenge during the 100° or so of crankshaft rotation that the exhaust port remains open.

Blowdown As the piston falls, it first uncovers the exhaust port and then, 5° or 10° of crankshaft rotation later, the transfer port. Blowdown occurs during this brief period that, at wide-open throttle, occupies no more than one or two thousandths of a second. In spite of its brevity, the blowdown phase is the primary mechanism for evacuating the cylinder.

The rapid opening of a port releases a high-pressure slug of exhaust gas that trails a low-pressure zone or wave in its wake. Cylinder pressure momentarily drops below atmospheric pressure. Responding to the pressure differential, the fresh charge moves through the transfer port to fill the cylinder. At part throttle, crankcase pressure is less than cylinder pressure. Were it not for the drop in cylinder pressure that accompanies blowdown, two-cycle engines would not run.

The need to accelerate exhaust gases quickly explains why exhaust ports for high-performance engines are rectangular rather than round. It also explains why we must keep these ports and mufflers free of carbon accumulations.

Exhaust tuning When a high-pressure wave encounters a solid obstacle or an abrupt change in

direction in the exhaust plumbing, it rebounds back to the exhaust port. These waves oscillate at the speed of sound and at a frequency determined by engine rpm. Where space permits, the length of the exhaust system can be tuned to reflect a high-pressure wave back to the exhaust port just as the cylinder fills to overflowing. The wave rams any fuel that spills out of the port back into the cylinder where it belongs. Of course, this works only over a narrow rpm range; at other speeds the wave can arrive early to the detriment of cylinder filling. In a similar manner, the intake tract can be tuned to maximize crankcase filling.

Spatial constraints make tuned exhaust and intake systems impractical for handheld equipment. About all that can be done is to arrange for a small boost from third-or fourth-order wave harmonics.

Charge scavenging What exhaust gas remains in the cylinder after blowdown must be scavenged by the fuel charge, which enters the cylinder at velocities as high as 65 m/s. Charge scavenging takes two forms, neither of which can entirely eliminate short-circuiting.

Short-circuiting Short-circuiting is the term for the way incoming fuel escapes out the exhaust, as if one were trying to fill a leaky bucket. Most of the leak can be laid to symmetrical timing.

Because piston motion controls port timing, the timing is symmetrical around BDC. For example, an exhaust port that opens 60 crankshaft degrees before bottom dead center must remain open for 60° after BDC. The exhaust port opens a few degrees before the transfer port. Otherwise, the cylinder would not blow down and very little fuel would be delivered. But opening the exhaust port early means that it stays open throughout the entire fuel transfer process.

The open exhaust port acts as an escape hatch for incoming fuel. How much fuel escapes combustion varies with port geometry, rpm, and throttle position. An idling motorcycle short-circuits as much as 70% of its fuel out the exhaust. On average, two-stroke engines waste between 25% and 35% of their fuel in this manner.

Cross scavenging Readers with long memories may recall the deflector pistons that were once standard ware on these engines ([Fig. 1-7](#)).

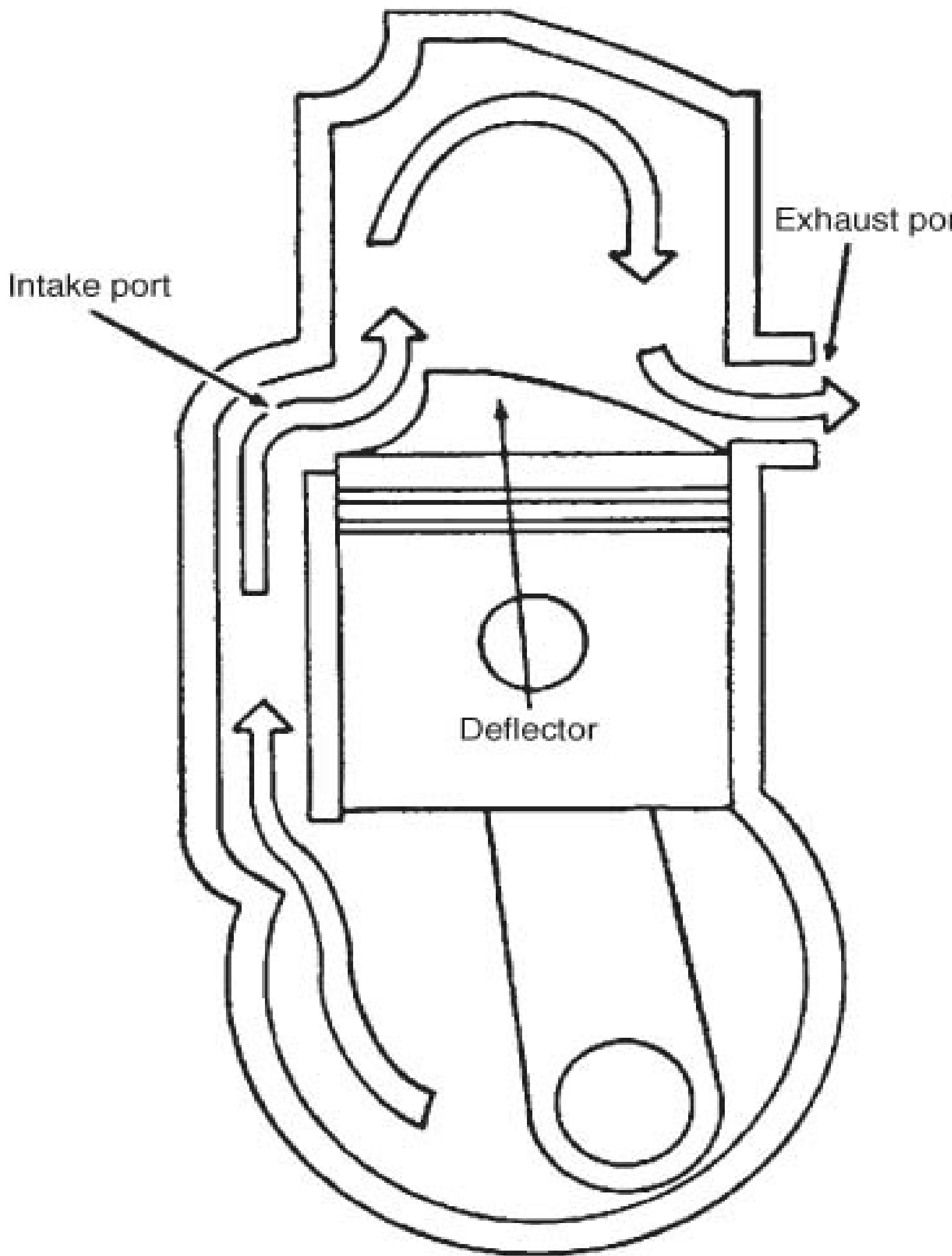

Fig. 1-7. *Cross-scavenged engines have the intake port 180° opposite the exhaust port. Incoming gas rebound upward off the deflector on the piston crown to give some protection against short-circuiting.*

The fuel charge enters through a single transfer port, rebounds upward off the deflector, and drives residual exhaust gases out the exhaust port. While this design works well at moderate speeds, at high speeds, the deflector can run hot enough to ignite the mixture. Nor does the simple trajectory made by the incoming charge impact the area just above the exhaust port, which remains a haven for exhaust gas. Other factors that mitigate against cross scavenging include the awkward shape of the combustion chamber and the weight penalty imposed by the deflector. But the single transfer port simplifies foundry work, which explains why American outboard manufacturers were among the last to abandon this approach.

Loop scavenging Current practice, based on work carried on in Germany during the 1920s, is to use loop, or Schnürle, scavenging. Multiple transfer ports are arranged around the cylinder periphery with their exit ramps angled to impart swirl to the charge (Figs. 1-8 and 1-9). The miniature cyclone fills the whole combustion chamber, sweeping exhaust gases out ahead of it. In addition, the rapidly spinning mass of fuel and air has integrity, that is, it hangs together so that less fuel short-circuits.

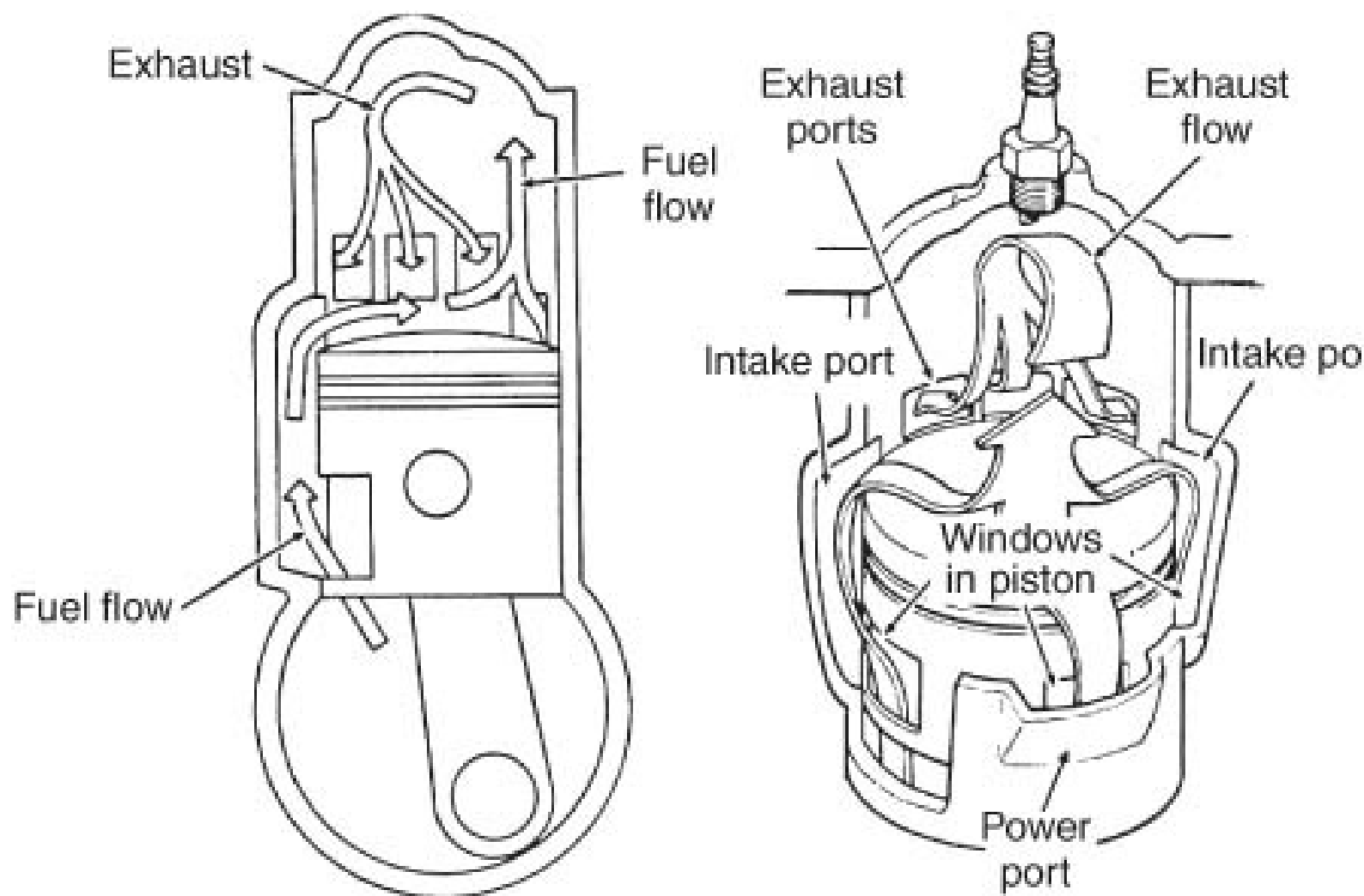

Fig. 1-8. *In a loop-scavenged engine the fuel charge enters through multiple transfer ports (called intake ports here) arranged around the periphery of the cylinder. Port exit angles to give swirl to the charge, which reduces short-circuiting. Windows in the piston skirt are an optional feature. OMC*

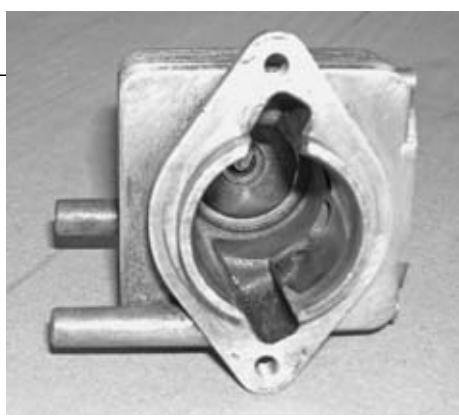

Fig. 1-9. This cylinder has what are sometimes called finger ports. That is, the transfer ports are open to the bore along their whole length. Looking carefully one can see the angled exit ramp at the upper end of lower port. Robert Shelby

Displacement

We class ships by tonnage, houses by square footage, and engines by the volume the piston displaces as it moves between centers. All things equal, an engine should develop power in proportion to its displacement.

$$\text{Displacement} = \text{bore} \times \text{bore} \times \text{number of cylinders} \times \text{stroke} \times 0.7858$$

For example, the Tanaka series TBC-2501 has a 34-mm bore and a 27-mm stroke. To perform the calculation, square the bore and multiply by the stroke:

$$34 \times 34 \times 1 \times 27 \times 0.7858 = 24526.39 \text{ mm}^2$$

To convert to cubic centimeters, divide by 1000:

$$24526/1000 = 24.5 \text{ cc}$$

To convert to cubic inches, multiply cubic centimeters by 0.061, which in this example gives 1.50 CID (cubic-inch displacement). To work the conversion the other way, multiply the CID by 16.387 to arrive at cubic centimeters.

Compression ratio

The compression ratio (CR) describes the amount of “squeeze” the piston applies to the air-fuel mixture prior to combustion. It is arrived at by dividing total cylinder volume, that is, the volume with piston at BDC, by the volume that remains when the piston rises to TDC. The latter figure is the clearance volume. Normally we take the manufacturer’s word for CR, since determining the clearance volume can become a bit hairy, especially when a domed piston is fitted.

Some manufacturers express CR as just described, which is geometrically accurate and yields impressively high numbers. Others provide the effective ratio, calculating swept volume as the volume the piston transverses after the exhaust port closes. Obviously, there can be no compression

with an open exhaust port. Effective CRs range from 6 to more than 8:1.

Up to a point, the higher the compression ratio the better. The limit is imposed by the tendency of the fuel, a tendency made worse by the presence of oil, to detonate. Normal combustion is an orderly process, initiated by the spark and moving out to fill the combustion chamber. Detonation occurs when the tag ends of the fuel charge, compressed and heated by the expanding flame front, suddenly explode (Fig. 1-10). Cylinder pressures skyrocket and, if detonation persists, the piston melts and crankpin bearings hammer flat.

Spark occurs ...

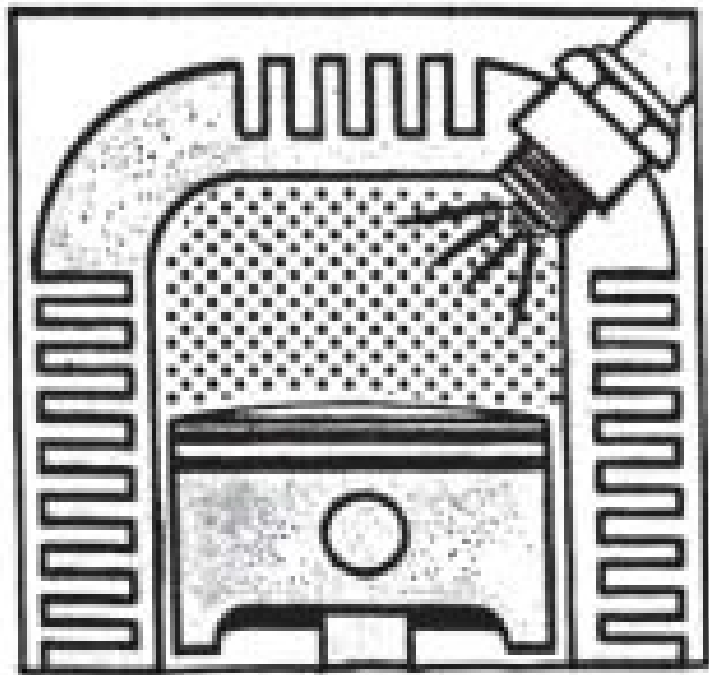

... Combustion begins ...

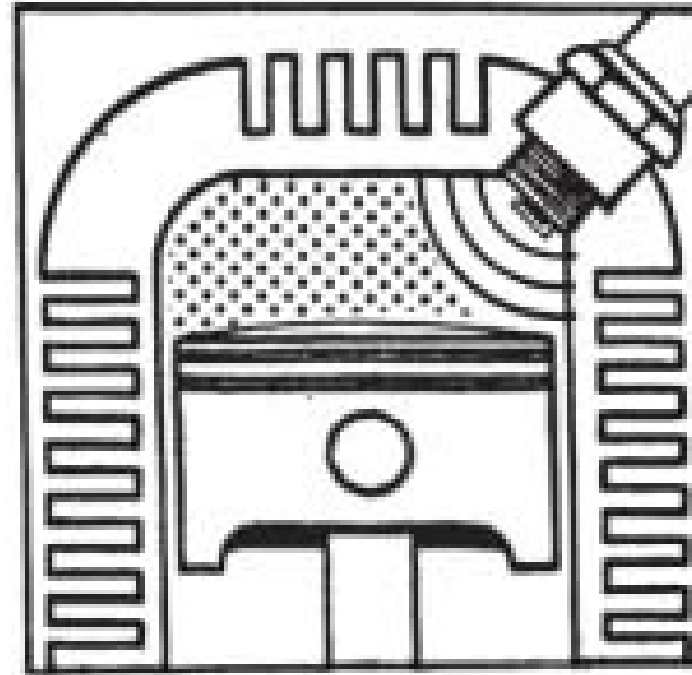

... Continues ...

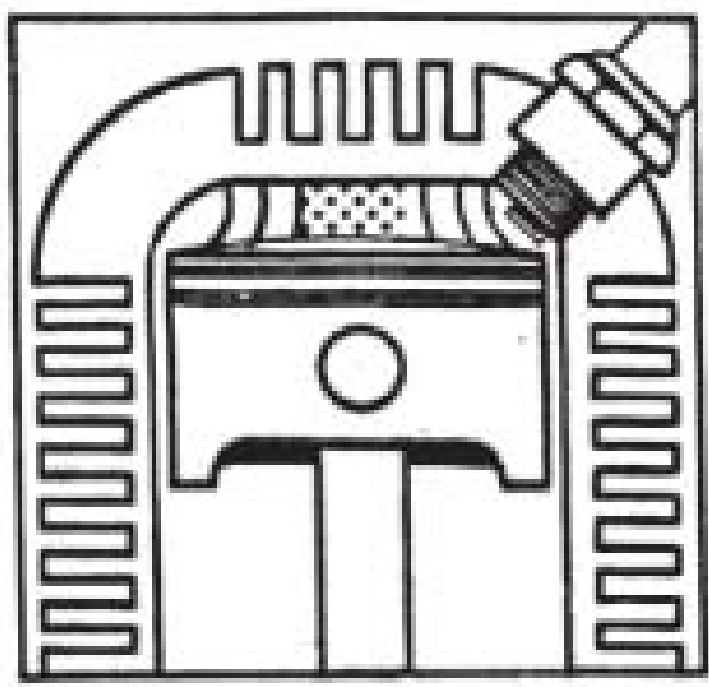

... Detonation.

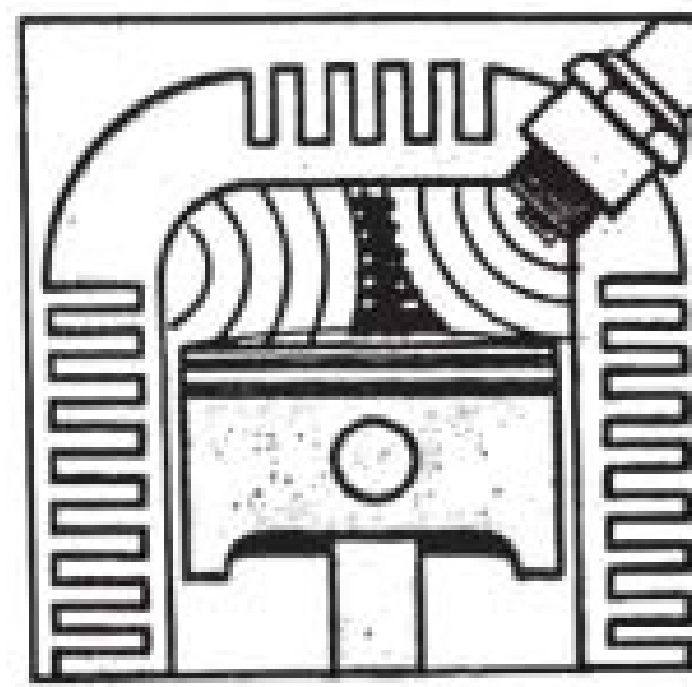

Fig. 1-10. As shown in this Champion Spark Plug drawing, detonation is a maverick form of combustion initiated late in the process, after normal ignition.

In addition to cylinder compression, two-strokes also develop crankcase compression. Since the work of compressing the air/fuel charge prior to delivery absorbs energy that could be better used to turn the crankshaft, designers limit crankcase compression to between 1.3 and 1.6:1. Pressures rarely exceed 6 psi.

Torque and horsepower

Near the end of the eighteenth century, James Watt observed that a mine pony tethered to a turnstile could lift 550 lb one foot per second, or 33,000 lb per minute. Horsepower was a brilliant sales tool that put steam engines into a context that potential customers could understand. In metric notation, one horsepower equals 0.746 kilowatt (kW).

Torque, or the instantaneous twisting force on the crankshaft, is the active component of horsepower. One foot-pound of torque is a twisting force generated by a one-pound weight on the end of a bar one foot long. Expressed metrically, 1 ft/lb equals 1.36 Newton meters (Nm) or 0.14 kilogram meters (kgm).

To determine torque output, researchers mount the engine on a dynamometer and measure the braking force required to bring the engine to a halt. Once torque is known, the conversion to brake horsepower (bhp) is simple:

$$\text{bhp} = (\text{torque} \times \text{rpm} \times 2 \pi) / 33,000$$

Thus, an engine that produces 2 ft/lb of torque at 7000 rpm has a power output of

$$\begin{aligned} \text{bhp} &= (2 \times 7000 \times 2 \times 3.14) / 33000 \\ \text{bhp} &= 2.66 \end{aligned}$$

We feel the effects of torque as the ability of vehicles to accelerate and as the refusal of handheld tools to bog down under sudden loads. Internal combustion engines generally develop their maximum torque at about two-thirds throttle.

$$\text{hp} = (\text{torque} \times \text{rpm}) / 5253$$

Peak hp occurs at full throttle or at some close approximation to it. The limiting factor is friction, especially friction between the piston rings and cylinder walls, which increases with speed even more rapidly than horsepower.

The horsepower rating of engines remains a formidable sales tool that, in the absence of standards, can be easily manipulated. Reputable small-engine manufacturers arrive at their horsepower numbers in accordance with the Society of Automotive Engineers (SAE) protocol J-1349. The test engine is tuned to laboratory precision, a process that includes decar-bonization after break-in, and its output measured at an ambient temperature 77°F (25°C) and an elevation of 100 m (328 ft) above sea level.

Since most engine makers follow this protocol, advertised horsepower can be used as a means of comparison between models and brands. But laboratory levels of tuning boost horsepower beyond levels experienced in the field. As a practical matter, customers can expect no more than about 85% of the horses promised.

sample content of Two-Stroke Engine Repair and Maintenance

- [Artisan Vegan Cheese.pdf, azw \(kindle\)](#)
- **[download The Inventor's Secret \(The Inventor's Secret, Book 1\)](#)**
- [click Renaissance Self-Fashioning, From More to Shakespeare](#)
- [click How Was It Possible?: A Holocaust Reader.pdf](#)

- <http://aircon.servicessingaporecompany.com/?lib/Crediting-God--Sovereignty-and-Religion-in-the-Age-of-Global-Capitalism.pdf>
- <http://www.satilik-kopek.com/library/Canon-EOS-Rebel-T5i-700D-Digital-Field-Guide.pdf>
- <http://redbuffalodesign.com/ebooks/Renaissance-Self-Fashioning--From-More-to-Shakespeare.pdf>
- <http://www.shreesaiexport.com/library/MariaDB-Crash-Course.pdf>